

Working in Power

MASTERNOVA i & MASTERNOVA

online UPS

30-100 kVA three-phase/single phase
250-800 kVA three-phase/three-phase

- LOCAL AREA NETWORKS (LAN)
- SERVERS
- DATA CENTERS

- INTERNET CENTERS (ISP/ASP/POP)
- INDUSTRIAL PLCS
- EMERGENCY DEVICES (LIGHTS/ALARM)

- ELECTRO-MEDICAL DEVICES
- TELECOMMUNICATIONS DEVICES
- INDUSTRIAL APPLICATIONS

MASTERNOVA

The **Masternova i** and **Masternova** range include 250-300-400-500-600-800 kVA three phase models and 30-40-60-80-100 kVA three/single phase. Both models are true online double conversion technology (VFI) with Inverter output isolation transformer.

MasterNOVA i 300-400-500 kVA, MasterNOVA 30-40-60-80-100 kVA are designed with output nominal power with power factor 0.9

The load is powered continuously by the inverter with a filtered, stabilised and regulated sinewave supply. The input and output EMI filters considerably increase the immunity of the load to mains disturbances and surges.

MasterNOVA provides maximum protection for vital “mission-critical” networks, security applications (electromedical) and industrial applications, thanks to its outstanding mechanical and electrical design.

- isolation transformer on the inverter
- extremely high short-circuit current
- sinusoidal absorption
(THDi up to 3% with CLEAN version)

Specific Solutions

MasterNOVA can be adapted to your requirements.

Please contact G-TEC Asia Pacific Pte Ltd to discuss specific applications and options

Main Features:

- Low harmonic pollution, input current THDi $\leq 3\%$
- Maximum reliability and power availability - connect up to 8 units in parallel or N+1 redundancy, UPS Group Synchroniser (UGS) and Parallel System Joiner (PSJ)
- High battery management:
 - Automatic battery test
 - Temperature compensated charging available
 - Recharge compensated for temperature
 - Battery care. Battery life span can be increased approximately by 20% more
- Emergency operation: the UPS can be set to operate only when the mains fails (for emergency lighting)
- Back feed protection: to avoid energy feeding back into the mains supply
- By pass may be deactivated to allow operation as a frequency converter (at 50 or 60 Hz), or as stabiliser
- Easy to maintain (front access).

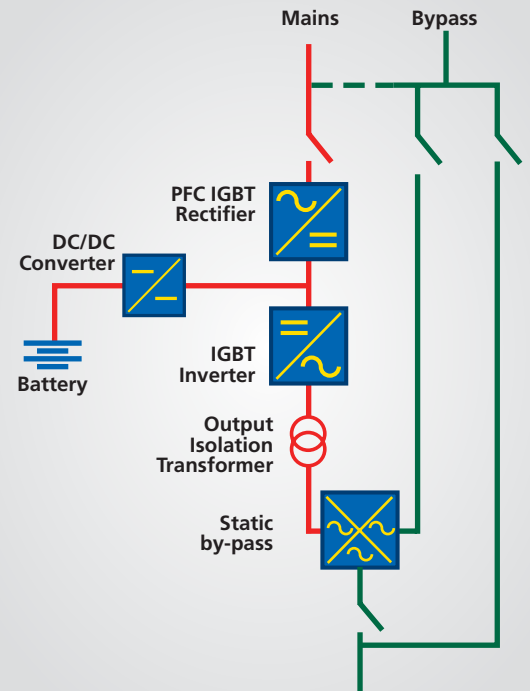

**MasterNOVA i Double-Conversion
True On-line Technology**

Simplified Maintenance

Access for maintenance is entirely from the front of the unit. Open the door and remove the protective panel (standards requirement) and the power components - mounted on a sliding tray - can be pulled out to provide easy access to all the electrical and electronic components for maintenance and repair work.

This particular feature means that the MTTR (Mean Time To Repair) is less than 30 minutes.

A large amount of maintenance information is available from the front mimic panel and LCD.

In addition system operating parameters are software configurable via a local PC to allow new functions to be added or adjustments made to operating specifications.



- Reliable, filtered, stabilised and regulated sinewave output (double on-line conversion technology VFI according to EN50091-3 specifications) with filters for atmospheric disturbance suppression
- MasterNOVA i achieved entirely with IGBT and with special DSP controlled IGBT Rectifier. Thus guarantees maximum performance and high quality power for any IT and industrial load.
- High reliability: IGBT technology, full microprocessor control with no-break static and manual bypasses
- High diagnostic capability - event log with 128 messages, status, measurement and alarm-available from the built-in LCD screen in several languages.
- The UPS may be configured with the RS232 serial port (flash upgradable)
- Reduced noise levels: high frequency inverter bridge used (>16 kHz: above audible range)
- Low loss high efficiency up to 94% in On-line mode utilizing IGBT technology and up to 98% in the other operating modes:
Economy Mode, Smart Active Mode, and Standby/Off Mode.
- Economy Mode: uses Line Interactive (VI) technology to power less critical loads from the mains supply for certain periods. The function can be set from the front panel keypad or remotely using software



DETAILED UPS PARAMETER DISPLAY

Powershield³ provides all the information required for first level diagnostics



BLOCK AND FUNCTIONAL DIAGRAMS

Powershield³ also displays the UPS in block format providing the user with information regarding operating status

Direct Connection with Ethernet Network

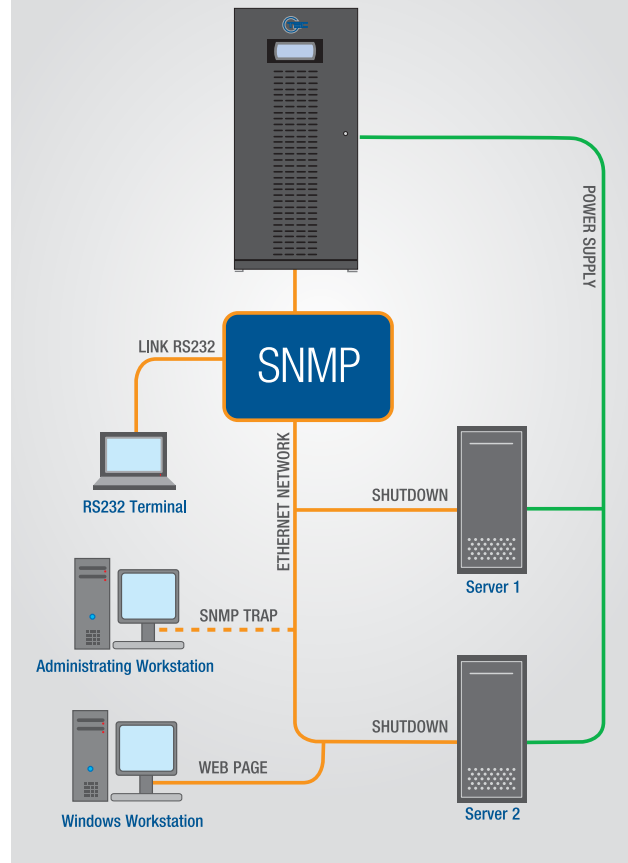

Communication Solutions

ADVANCED COMMUNICATION

- Compatible with TELEGUARD for remote maintenance
- Advance, multi-platform communication, for all operating systems and network environments:

PowerShield³ supervision and shut-down software included, with SNMP agent, for Window NT 4.0, Vista, XP; Mac OS 10.x, Linux, Novell operating systems. The UPS is equipped with a cable for direct connection to the PC (Plug and Play)

- Can also provide shut-down software for: IBM AIX; Free BSD; BSDI Unix; BSD/OS; SCO Unixware; SCO Openserver; Sun Solaris; Compaq True64; HP Unix; HP OpenVMS; HP OpenView; SGI Irix MIPS; NCR Unix
- Double RS232 serial port
- Network adapter slot for SNMP agent
- EPO (Emergency Power Off) shut down input contact
- Remote control panel (optional)

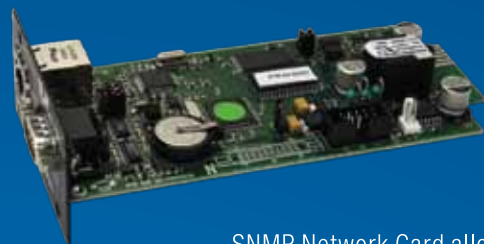

SNMP Network Card allows management of UPS across LAN using any of the main network communication protocols - TCP/IP and network interface via SNMP

TECHNICAL **ASSISTANCE** SERVICE

UPService, our technical assistance facility uses highly trained engineers to provide a reliable and competent technical support and after-sales service.

UPService can provide customers with:

- A dedicated CALL CENTRE for connection to the UPService organisation. UPService personnel are always available and ready to provide advice and assistance regarding UPS installation, maintenance, fault finding and repair.
- FAST & READY A fast repair on site is guaranteed through the use of state-of-the-art UPS technology and the professionalism of the UPService personnel and Authorised Assistance Centres. UPService guarantees that failed parts are replaced with original ones, tested and updated in order to maintain the safety, reliability and operating characteristics of the UPS.
- COMMISSIONING AND START-UP UPService can provide assistance during commissioning and startup of the UPS equipment on-site with additional training during handover to site personnel. UPService engineers can also verify site suitability, analyse and advise on potential problems, and disconnect and relocate equipment. UPService recommend that all hardwired installations are commissioned by UPService engineers.
- MAINTENANCE CONTRACTS can be provided by UPService to minimise response times and repair costs. Contracts range from periodic inspections to comprehensive cover including labour and materials.
- The TELEGUARD software package provides remote 24x7 UPS supervision. TeleGuard can interrogate G-TEC UPS connected to a local telephone line to check on their operating logs and system status. Should the UPS report an alarm condition, the UPService Call Centre is immediately notified and a dedicated customer response activated. Routine site reports can be sent automatically to customer personnel.
- UPService organises regular TECHNICAL TRAINING COURSES for UPS operators and installers.



TECHNICAL **ASSISTANCE** SERVICE

MASTERNOVA

3 Phase Input/ 1 Phase Output

TECHNICAL SPECIFICATION					
Model	30 (3/1)	40 (3/1)	60 (3/1)	80 (3/1)	100 (3/1)
INPUT					
Rated Voltage & Range (V)	400Vac 3 phase +20% -25%				
Frequency & Range	50Hz/ 60Hz auto sensing, 45Hz to 65Hz				
Input power factor & THDi	≥0.9 & ≤5% with CN option				
BYPASS					
Rated Voltage (V)	230Vac (selectable from 220V to 240V), ±15% (adjustable from ±10% to ±25%)				
Frequency & Range (Hz)	50Hz / 60Hz auto sensing ±2%. (Selectable from ±1% to ±6%)				
BATTERY					
Type	VRLA battery; Vented lead acid battery & NiCad battery				
Charging Method	Two level & Cyclic charging according to EN 50272-2				
Ripple voltage	Approximately 0%				
INVERTER OUTPUT					
Rated Power	30kVA/ 27kW	40kVA/ 36kW	60kVA/ 54kW	80kVA/ 72kW	100kVA/ 90kW
Rated Voltage & Stability (V)	220V / 230V / 240V, Single phase ±1%				
Frequency & Stability (Hz)	50Hz/ 60Hz ±0.05% at free running; ±2% at synchronized mode (adjustable ±1% to ±6%)				
Dynamic Stability (V)	±5% within 20ms to standard EN62040-3, class 1				
Overload	110% for 60mins; 125% for 10mins; 150% for 60sec				
ENVIRONMENTAL DATA					
Operating Temperature	0°C to 40°C				
Relative Humidity	<95% non condensing				
Colour	RAL 7035 light grey				
Efficiency	Up to 98% at ECO mode				
Compliance Standard	European Directive LV2006/95/EC, EMC 2004/108/EC, Safety: IEC EN62040-1; EMC: IEC EN62040-2; Performance & Test: IEC EN62040-3				
Noise level @ 1m (dBA)	62				63
Dimension L x D x H (mm) 6 Pulse	555 x 740 x 1400		800 x 740 x 1400		800 x 800 x 1900
CN version	825 x 740 x 1400		1070 x 740 x 1400		-
Weight (kg)	290	340	440	520	650
UPS Monitoring Software <i>Consult GTEC for details</i>	WindowsXP (x86 & x64), 2003 (x86, x64 & ia64), Vista 2008, 7 / Novell Netware / Linux Redhat x86; x64, ia64; Linux SuSE x86, x64; Linux Debian ia64, x64 MacOS X PowerC, Universal / Sun Solaris Sparc / Compac Tru64 / IBM AIX/ HP UX & Open VMS / FreeBSD / OpenBSD / SGI Irix / SCO OpenServer, Unixware / HP-OpenView				

UPS specification and data may subject to change for improvement without prior notice

MASTERNOVA i

3 Phase Input/ Output (full IGBT UPS)

TECHNICAL SPECIFICATION				
Model	250i	300i	400i	500i
INPUT				
Rated Voltage & Range (V)	400Vac, 3 phase ±20%			
Frequency & Range	50Hz/ 60Hz auto sensing, 45Hz to 65Hz			
Input power factor & THDi	≥0.99 & ≤3%			
BYPASS				
Rated Voltage (V)	380V / 400V / 415V ±15% (adjustable from ±10% to ±25%)			
Frequency & Range (Hz)	50Hz / 60Hz auto sensing ±2%. (Selectable from ±1% to ±6%)			
BATTERY				
Type	VRLA battery; Vented lead acid battery & NiCad battery			
Charging Method	Two level & Cyclic charging according to EN 50272-2			
Ripple voltage	Approximately 0%			

MASTERNOVA i

3 Phase Input/ Output (full IGBT UPS)

Model	250i	300i	400i	500i
	INVERTER OUTPUT			
Rated Power	250kVA/ 200kW	300kVA/ 270kW	400kVA/ 360kW	500kVA/ 450kW
Rated Voltage & Stability (V)	400V 3 phase + N (selectable 380V & 415V) ±1%			
Frequency & Stability (Hz)	50Hz/ 60Hz ±0.05% at free running; ±2% at synchronized mode (adjustable ±1% to ±6%)			
Dynamic Stability (V)	±5% within 20ms to standard EN62040-3, class 1			
Overload	110% for 60mins; 125% for 10mins; 150% for 60sec			
	ENVIRONMENTAL DATA			
Operating Temperature	0°C to 40°C			
Relative Humidity	<95% non condensing			
Colour	RAL 7035 light grey			
Efficiency	Up to 98% at ECO mode			
Compliance Standard	European Directive LV2006/95/EC, EMC 2004/108/EC, Safety: IEC EN62040-1; EMC: IEC EN62040-2; Performance & Test: IEC EN62040-3			
Noise level @ 1m (dBA)	68	70 - 72		
Dimension L x D x H (mm)	1000 x 850 x 1900	1500 x 1000 x 1900		2100 x 1000 x 1900
Weight (kg)	1000	1550	1750	2000
UPS Monitoring Software <i>Consult GTEC for details</i>	WindowsXP (x86 & x64), 2003 (x86, x64 & ia64), Vista 2008, 7 / Novell Netware / Linux Redhat x86; x64, ia64; Linux SuSE x86, x64; Linux Debian ia64, x64 MacOS X PowerC, Universal / Sun Solaris Sparc / Compac Tru64 / IBM AIX/ HP UX & Open VMS / FreeBSD / OpenBSD / SGI Irix / SCO OpenServer, Unixware / HP-OpenView			

UPS specification and data may subject to change for improvement without prior notice

MASTERNOVA

3 Phase Input/ Output (12 Pulse Rectifier)

	TECHNICAL SPECIFICATION					
Model	250	300	400	500	600	800
Rated Power (kW)	200	240	320	400	480	640
	INPUT					
Rated Voltage & Range (V)	400Vac, 3 phase +20% -25%					
Frequency & Range	50Hz/ 60Hz auto sensing, 45Hz to 65Hz					
Input power factor & THDi	<5%; ≥0.93			<7%; ≥0.84		
	ENVIRONMENTAL DATA					
Operating Temperature	0°C to 40°C					
Relative Humidity	<95% non condensing					
Colour	RAL 7035 light grey					
Efficiency	Up to 98% at ECO mode					
Compliance Standard	European Directive LV2006/95/EC, EMC 2004/108/EC, Safety: IEC EN62040-1; EMC: IEC EN62040-2; Performance & Test: IEC EN62040-3					
Noise level @ 1m (dBA)	65		75		78	
Dimension L x D x H (mm)	1630 x 850 x 1900		1630 x 1000 x 1900	3200 x 1000 x 1900		4400 x 1000 x 1900
Weight (kg)	1700	1770	2045	3800	4200	5450
UPS Monitoring Software <i>Consult GTEC for details</i>	WindowsXP (x86 & x64), 2003 (x86, x64 & ia64), Vista 2008, 7 / Novell Netware / Linux Redhat x86; x64, ia64; Linux SuSE x86, x64; Linux Debian ia64, x64 MacOS X PowerC, Universal / Sun Solaris Sparc / Compac Tru64 / IBM AIX/ HP UX & Open VMS / FreeBSD / OpenBSD / SGI Irix / SCO OpenServer, Unixware / HP-OpenView					

Bypass; Battery & Inverter Output same as MasterNOVA i

UPS specification and data may subject to change for improvement without prior notice

THDi is ≤ 3% for CN version